

# SENKO

## INSTRUCTION MANUAL



Solid fuel  
COOKERS

SG-60, SG-75 and SG-90

SN-EN-5/18

For a perfect  
warm home!







Dear client, thank you for choosing a SENKO cooker!

This product was designed and manufactured to its minutest details in order to fulfill your every need for functionality and safety.

This *Instruction manual* will teach you to operate your cooker properly, so please read the manual carefully before using the cooker.

Senko management

Symbols used in this *INSTRUCTION MANUAL*:

- ATTENTION  • WARNING 
- SAFETY  • ADVICE AND RECOMMENDATIONS 

# CONTENTS

<b>1. GENERAL</b> .....	4
1.1. FUEL .....	6
1.2. FEEDING .....	6
1.3. CHIMNEY .....	7
1.3.1. CHIMNEY CAP .....	7
1.3.2. CHIMNEY FUNCTION .....	8
1.4. INSULATION .....	10
<b>2. WARNINGS AND SAFETY</b> .....	10
<b>3. TECHNICAL FEATURES</b> .....	11
<b>4. INSTALLATION</b> .....	14
4.1. POSITIONING .....	14
4.2. CHIMNEY PREPARATION AND CONTROL .....	16
4.3. CONNECTING TO CHIMNEY .....	16
4.4. FRESH AIR VENTS .....	20
4.5. OVEN THERMOMETER .....	22
4.6. INSTALLATION TESTING .....	22
<b>5. HANDLING THE PRODUCT</b> .....	23
5.1. DIRECTING THE FLUE GAS .....	23
5.2. AIR ADJUSTMENT AND REGULATION .....	24
5.3. FIREBOX GRATE .....	25
5.4. FIRING .....	26
5.4.1. PROCEDURE .....	26
5.4.2. OPTIMUM USE VALUES .....	26
5.4.3. ADDING FUEL .....	27
5.4.4. FEEDING IN TRANSITION PERIOD .....	28
5.5. OVEN DOOR .....	28
5.6. FUEL BOX .....	29
5.7. HEIGHT ADJUSTMENT .....	30

<b>6. CLEANING</b> .....	30
6.1. CLEANING THE FLUE GAS CHANNEL .....	31
6.1.1. COOKERS SG-75 and SG-90 .....	31
6.1.2. COOKER SG-60 .....	32
<b>7. MAINTENANCE</b> .....	33
7.1. OLD COOKER DISPOSAL .....	34
7.2. SPARE PARTS .....	34
<b>8. MALFUNCTIONS / CAUSES / SOLUTIONS</b> .....	35
<b>9. TECHNICAL SUPPORT</b> .....	36
<b>10. TECHNICAL DATA</b> .....	37
<b>11. TERMS OF WARRANTY</b> .....	38
<b>WARRANTY</b> .....	39
<b>INSTALLATION REPORT</b> .....	40
<b>CE MARKING</b> .....	41

# 1. GENERAL

Classical solid fuel cookers

- ◆ E 2560, E 2860 SG-60
- ◆ E 2375, E 2675 L SG-75
- ◆ E 2375, E 2675 D SG-75
- ◆ E 2390, E 2690 L SG-90
- ◆ E 2390, E 2690 D SG-90

are models from the SENKO cookers palette which can accommodate your needs in the best possible way. Therefore, we ask you to **CAREFULLY READ THESE INSTRUCTIONS**, which will help you to achieve the best possible results already during the initial use.



**The manufacturer is not responsible for any consequences** (people or animal injuries or property damages) **resulting from failure to comply with this *Manual***. The cooker is hot during operation and **the use of protective heat insulated gloves is compulsory during handling**. Children and infirm individuals are not allowed to handle the cooker.



The external appearance of the cooker is shown on the first page of this Manual. Cooker principal parts are made of stainless steel plates and castings of quality grey cast. The cookers are produced with flue gas connection point on the left or the right side. **When ordering the cooker or the spare parts, it is necessary to state its full designation**, for example: cooker E 2375 D SG-75; which means that the flue gas connection is on the right side, if the cooker is observed frontally.



The cookers are manufactured in accordance with the EN 12815 standard and comply with all the requirements set by this standard.

These SENKO cookers are intended **for cooking, baking and space heating!**

The cooker is packaged in a EURO pallet. During transport, the cooker must be properly fastened in order to prevent tumbling or damages. **The standard delivered cooker set consists from:**

- cooker,
- instruction manual,
- chimney terminal extension (22),
- cooker cleaning tool (23).

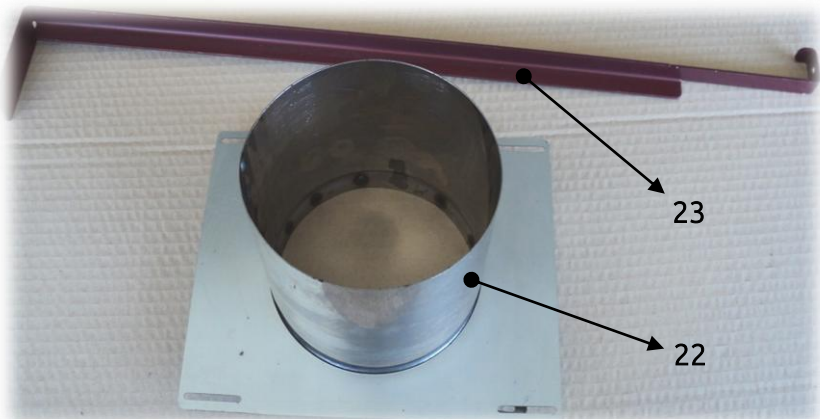

Figure 1



**CAUTION!** The cooker weighs between 130 and 200 kg. Extra caution is necessary when unloading, transferring, moving and installing the cooker in order to avoid physical injury.

## 1.1. FUEL

The use of moist and low-calorie wood is not recommended. The **wood moisture must be lesser than 17%**. The energy content of moist wood is low, at approx. 2,3 kWh/kg and it greatly pollutes the door glass, as well as the chimney and the cooker.



Use only recommended fuel:



- **wood:** common beech, common hornbeam, oak, black locust  
⇒ air dried for a minimum of 2 years  
⇒ relative humidity 15-17%, energy content at approx. 4,2 kWh/kg
- **wood briquettes:** energy content at approx. 4,4 kWh/kg

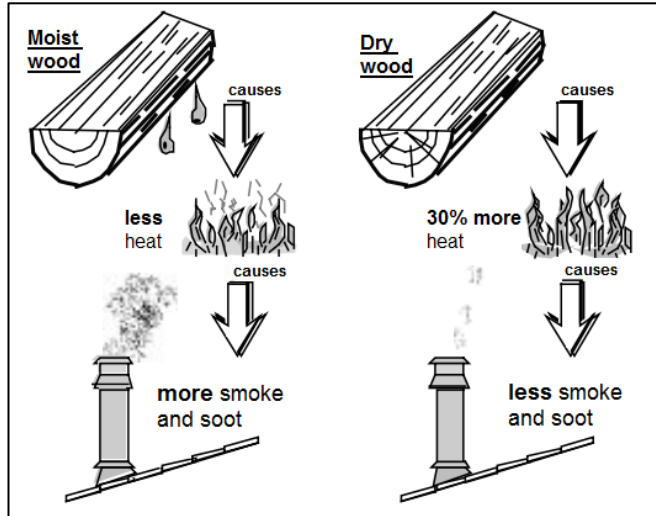

## 1.2. FEEDING

- manually when necessary
- we recommend the **logs** to be of 50 x 50 mm **vertical cut**, up to 2/3 of the firebox length
- use smaller logs for a more intensive fire, and more massive logs to maintain fire
- **the minimum distance between the logs** must be 1 cm, the same distance of 1 cm applies for the briquettes
- to maintain constant oven temperature, add smaller quantities of fuel occasionally ⇒ approx. 0,5 kg
- it is **necessary to use protective heat insulated gloves** when adding fuel to the firebox
- protective heat insulated gloves must also be used when opening and closing the oven and firebox door and removing the tray from the oven and ash box.



### 1.3. CHIMNEY



The cooker is connected to the chimney via **120 mm diameter sliding rosette**. It is necessary to execute the connection of the rosette and the chimney tightly and impermeably. **If the cooker is separated from the chimney opening (not recommended)** the connection is made via **standard 120 mm diameter smoke venting pipe** – see *chapter 4.3*.



We also advise to equip the chimney with **solid material and possible condensation products collection chamber** and to install the chamber in question beneath the smoke channel inlet, in a manner which allows easy access and inspection via impermeable door.



#### IMPORTANT

- **BEFORE** connecting to the chimney it is necessary always to make a calculation (according to EN 13384 and all other standards for the chimney dimensioning)!
- The chimney has a very important function of the smoke exhaust at solid fuel heating devices and therefore **MUST BE well and properly dimensioned!**

#### 1.3.1. CHIMNEY CAP



Chimney cap must fulfill the following prerequisites:

- **identical internal diameter** to that of the chimney,
- operational **exit cross-section no less than the double inner diameter of the chimney** – see  $B \geq 2 \times A$  in the Figure beside,
- constructed to **prevent rain, snow, leaves and other foreign bodies from entering** the chimney,
- constructed to **enable expulsion of combustion products in case of wind from any direction and incline**,
- installed to **enable proper dispersion and dilution of combustion products outside the reflux zone (backflow)** because the counter pressure occurs here. Therefore, it is necessary to adhere to limitations listed in *Figure 2*,
- **mechanical appliances for flue gases suction are not allowed.**

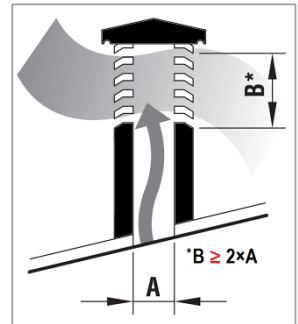



FLAT ROOF

PITCHED ROOF

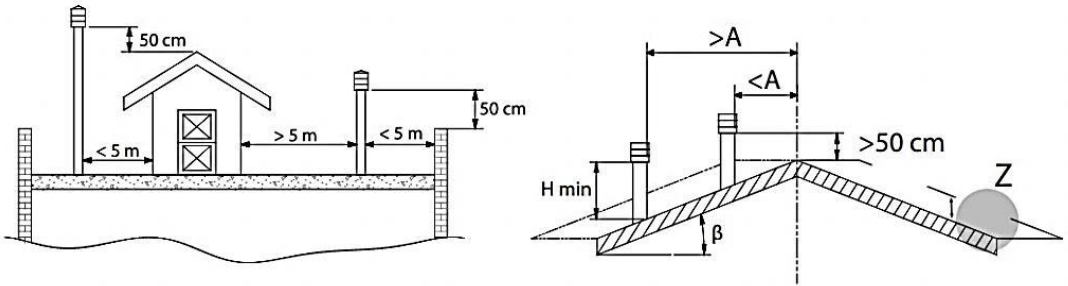

Figure 2

Z=REFLUX ZONE

Roof slope	Distance between the roof ridge and the chimney	Minimum chimney height (measured from the roof surface)
$\beta$	$A, m$	$H_{min}, m$
15°	< 1,85	0,5 m above the roof ridge
	> 1,85	1 m from the roof
30°	< 1,5	0,5 m above the roof ridge
	> 1,5	1,3 m from the roof
45°	< 1,3	0,5 m above the roof ridge
	> 1,3	2 m from the roof
60°	< 1,2	0,5 m above the roof ridge
	> 1,2	2,6 m from the roof

### 1.3.2. CHIMNEY FUNCTION

Among all the meteorological and geographical factors that influence the chimney function (rain, fog, snow, insolation period, etc.) **the wind is most certainly the crucial one.** Apart from the pressure caused by the temperature difference between the flue gases and the outer chimney air, there is another type of pressure – **wind dynamic pressure.**



Ascending wind ALWAYS has the effect of increasing the pressure, i.e., underpressure (flue draught), provided the chimney is properly installed. Descending wind ALWAYS has the effect of decreasing the draught  $\Rightarrow$  overpressure occurs. Apart from wind direction and velocity, chimney position in relation to the house roof and surrounding area is also important (Figure 3).

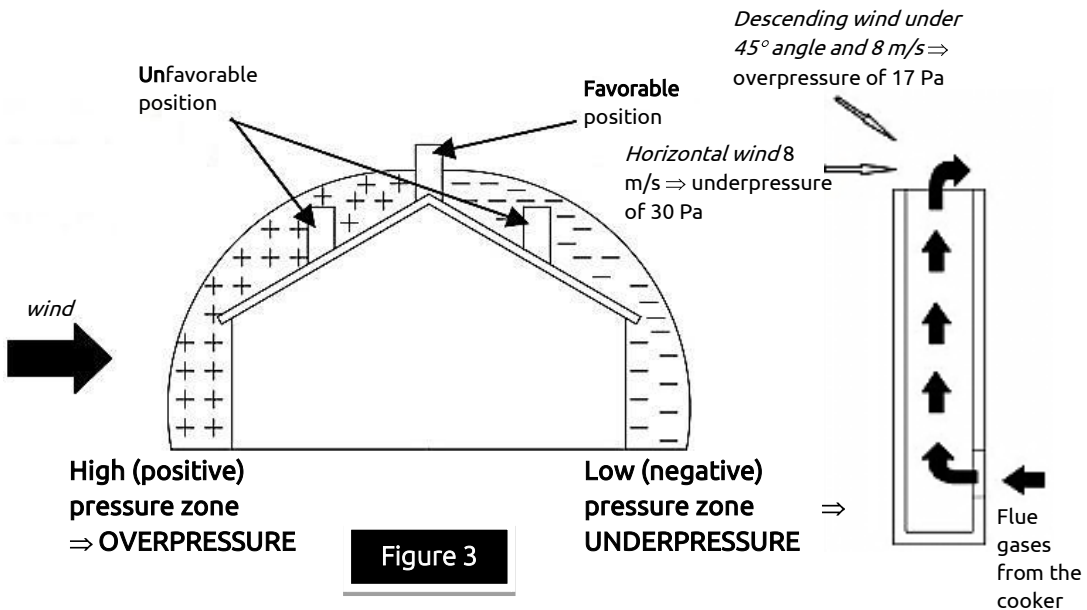

The wind also influences the chimney function indirectly by creating areas of high (overpressure) and low (underpressure) pressure, both inside and outside the residential area (Figure 4).

Pressure that facilitates chimney function can occur in rooms directly exposed to the wind (B), but it can also adversely affect the chimney through external pressure if the chimney is situated on the side exposed to wind (A). Contrary to that, underpressure can occur in lee rooms (C), adversely affecting functions of the chimney situated on the opposite side (D) from the wind direction.

Descending  
wind

Figure 4

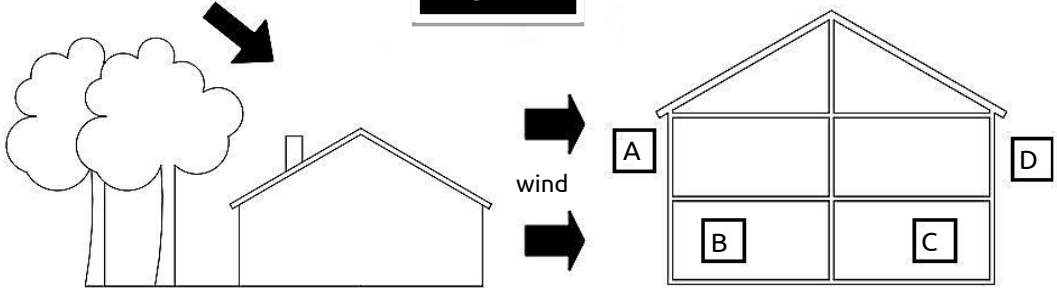

A-B zones in overpressure  
C-D zones in underpressure

## 1.4. INSULATION

Cooker is to the outer surfaces isolated with chamotte plates 20 mm thick. The sides are chamber derived and cooled with the natural air circulation. The depth of the chamber is 25 mm. Other parts of the cooker interior are lined with chamotte brick, 40 mm thick.

## 2. WARNINGS AND SAFETY

When connecting the cooker to the chimney, **adhere to national and European norms and local regulations.**



### **PROCEDURE IN CASE OF CHIMNEY FIRE**

*In case of chimney fire, close the openings for the air inlet and **DON'T open the firebox door.** Extinguish the fire using appropriate fire extinguishers. **NEVER EXTINGUISH A FIRE WITH WATER!** In case of fire also call the local fire department. Comply with local regulations for fire protection!*



Prior to use, verify with the local authorized chimney-sweeper whether **the cooker is properly connected to the chimney** (the chimney-sweeper must complete the installation report at the end of this *Manual*).



Special attention must be paid that there is enough air for combustion being supplied to the room cooker is installed in.



### 3. TECHNICAL FEATURES

SENKO cookers SG are intended for cooking, baking and household heating. They are equipped with an oven just like the traditional kitchen cooker. Cookers are suitable for installation between other kitchen appliances (with ensuring minimum safety distances – see *chapter 4.1.*) without heating risks.

They are made of **stainless steel plates and castings of quality grey casts**. The cooking plate (1) is made of 8 mm thick steel plate OR 6 mm glass ceramic cooking plate CERAN® (only at certain cooker models). Cooker interior is lined with chamotte.

The fuel box (12) is on the frontal side, at the bottom, just above the manual primary air regulator (10) and the ash box (11). Above them is a firebox (6) with a grate (16) and the oven (7) with door and thermometer (18).

Also, the cooker is on the front equipped with two handles, one serves as a flue gas deflector (14) and is located on the side where is the chimney connection point, while the other (15) serves as a lever for moving the firebox grate (16) – *only at cookers SG-75 and SG-90*.

The following figure display the schematic of the cookers and their accompanying parts.

# SCHEMATIC DISPLAY FOR COOKERS SG-75 and 90

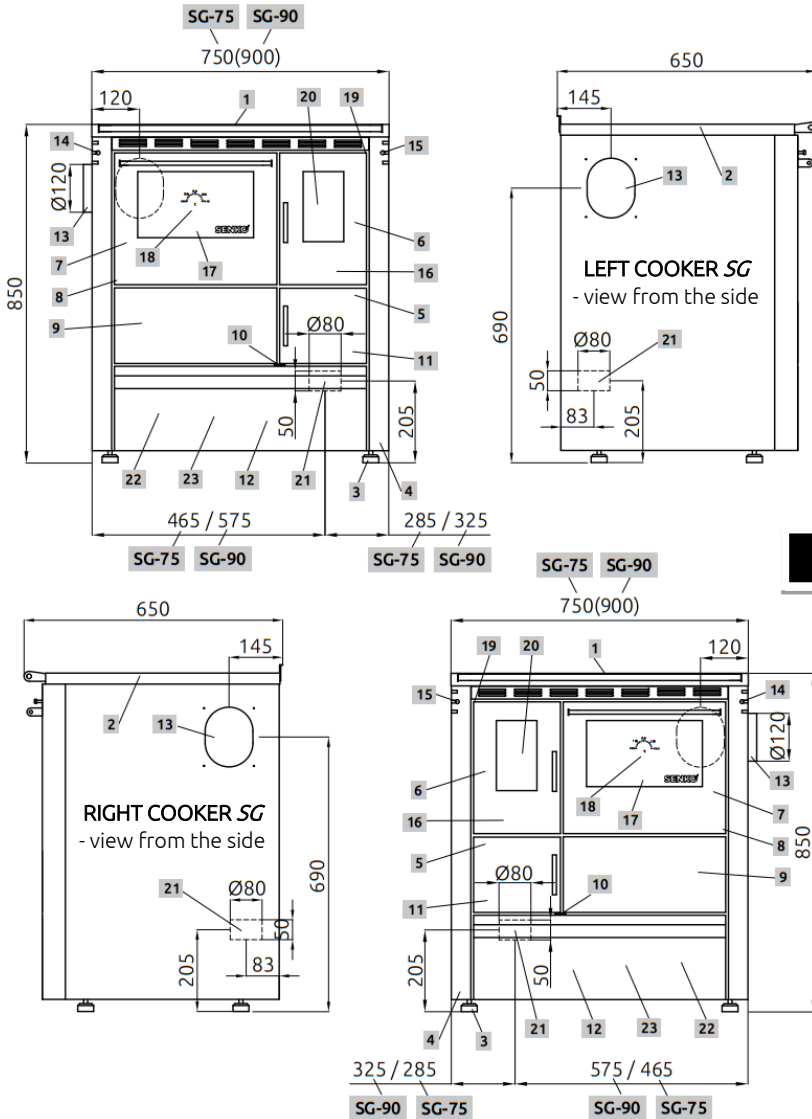
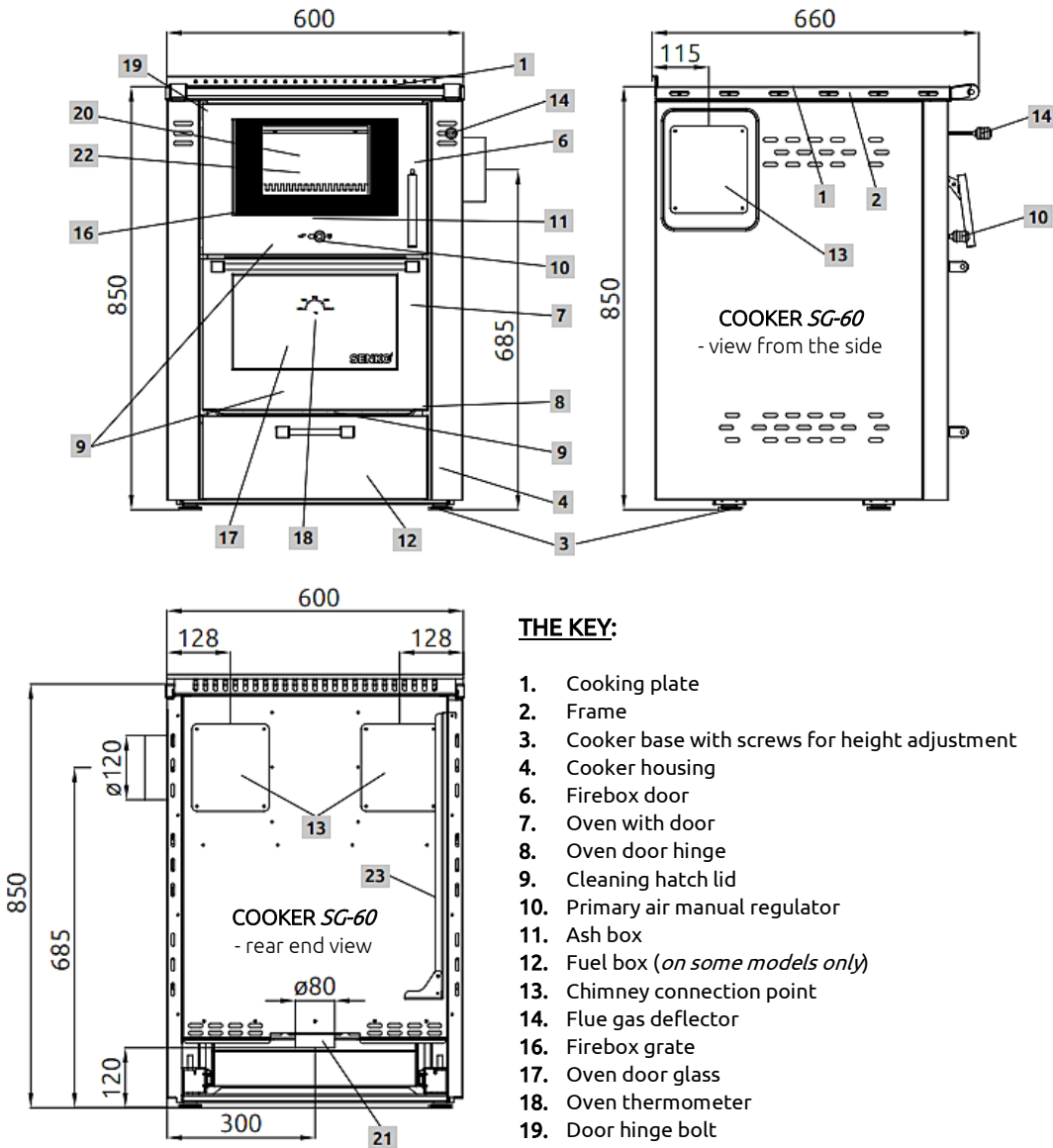

**Figure 5a**

## THE KEY:

- |  |                                  |  |
|--|----------------------------------|--|
| 1. Cooking plate                                 | 9. Cleaning hatch lid            | 19. Door hinge bolt                    |
| 2. Frame   | 10. Primary air manual regulator | 20. Firebox door glass                 |
| 3. Cooker base with screws for height adjustment | 11. Ash box                      | 21. Primary air inlet hatch            |
| 4. Cooker housing                                | 12. Fuel box                     | 22. Chimney connection point extension |
| 5. Lower door                                    | 13. Chimney connection point     | 23. Cooker cleaning tool               |
| 6. Firebox door                                  | 14. Flue gas deflector           |  |
| 7. Oven with door                                | 15. Handle for grate moving      |  |
| 8. Oven door hinge                               | 16. Movable grate                |  |
|  | 17. Oven door glass              |  |
|  | 18. Oven thermometer             |  |

**SCHEMATIC DISPLAY FOR COOKER SG-60**



**THE KEY:**

1. Cooking plate
2. Frame
3. Cooker base with screws for height adjustment
4. Cooker housing
6. Firebox door
7. Oven with door
8. Oven door hinge
9. Cleaning hatch lid
10. Primary air manual regulator
11. Ash box
12. Fuel box (*on some models only*)
13. Chimney connection point
14. Flue gas deflector
16. Firebox grate
17. Oven door glass
18. Oven thermometer
19. Door hinge bolt
20. Firebox door glass
21. Primary air inlet hatch
22. Chimney connection point extension
23. Cooker cleaning tool

**Figure 5b**

## 4. INSTALLATION

Once you have removed packaging from the cooker, it is necessary to **make a detailed inspection in order to determine any potential damages** that might have occurred during transport. Any detected damages must instantly be reported to the manufacturer.



In places of any connection points on the cooker (chimney, air inlet), **inspection hatches must be installed for system maintenance and servicing purposes.**

### 4.1. POSITIONING

A spirit level must be used to place the cooker in a horizontal position with no incline. It is necessary to ensure **the minimum distance of the cooker from any flammable objects**; such as wood, chipboard, cork and similar. If the materials are easily combustible such as PVC, polyurethane and similar, the necessary safety distances need to be doubled.



**The minimum distance from any flammable surfaces** above is 1000 mm and in front of the cooker is 800 mm, and 200 mm in all other directions.



When mounting the cooker on the floor made from easily combustible material (**wooden floors**), the cooker must be **mounted on an insulating non-combustible surface.**

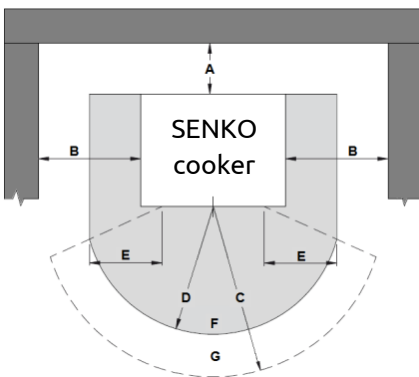

A	200 mm from the rear wall
B	200 mm from the side wall
C	800 mm from the front side
D	500 mm floor protection
E	300 mm (measured from the maximum angle of firebox door opening)
F	Floor protection
G	Radiation area

A cooker **should not be placed** in rooms where there are gas stoves or cookers, and in the bathroom, in buildings intended as laundries or similar. The same applies for **rooms or flats with air circulation or hot air circulation**





with ventilation systems (air condition, extractor or kitchen hoods), EXCEPT if such ventilation systems have safety mechanisms, which sustain the air pressure above 4 Pa in a room, where the cooker is mounted or in rooms which are in direct contact with exterior air.



It is recommended to place the cooker as close as possible to the chimney hole, i.e. next to the chimney hole itself in order to avoid using an additional smoke uptake pipe (Figure 6a)!



If you want to set the cooker **between the kitchen units**, it is necessary to ensure the minimum distances shown in the figure below.

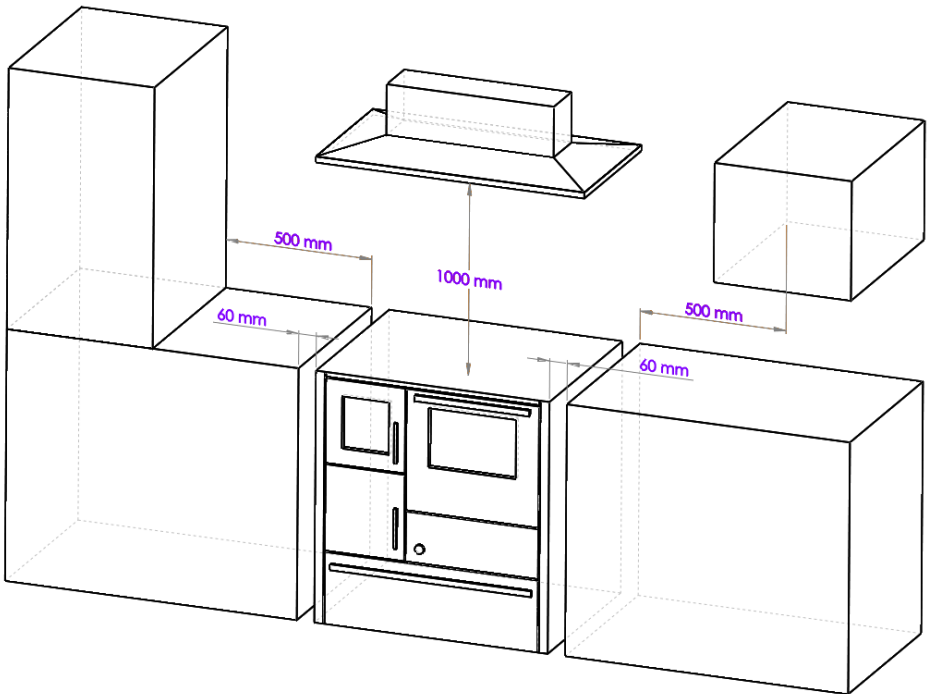

The distance between the cooker and kitchen element is intended for air circulation (cooling) – see the Figure above.



Here also you should take care on how to ensure **access to a cooker for maintenance and servicing**.



## 4.2. CHIMNEY PREPARATION AND CONTROL

Prior to cooker mounting, it is necessary to check the chimney – the diameter, height, possible clogging or damages. The chimney must be **certified by an authorized local chimney-sweeper.** The effective **chimney height** must be **at least 5 meters** from the point of flue gases outlet (*Figure 6b*).



**Flue draught** must be within parameters  $12 \pm 2$  Pa.

The chimney must be **at least 0,5 meters above the roof ridge** (see *Figure 2*). **The minimum distance between the two connections on the same chimney must be 60 cm** (*Figure 6d*).



Chimney diameter is chosen according to information provided by the chimney manufacturer – e.g., for flue draught of 12 Pa, the diameter is usually 130 mm.

**The chimney must be smooth on the inside, well insulated and well fastened.** All cleaning hatches must be well fastened. All gaskets must be regularly inspected and replaced when necessary.

## 4.3. CONNECTING TO CHIMNEY

When connecting the cooker to the chimney it is necessary to adhere to local, national and European regulations (norms) – **DIN 4705**.

It is necessary to ensure that **the connection between the cooker and the chimney is executed tightly and impermeably.** Smoke outlet pipe must have a **suitable incline** (minimum 3°) in cases where the cooker is removed from the chimney opening.

**Smoke outlet pipe must not penetrate into the chimney clear opening** (*Figure 6c*).



Differences between the proper and improper connection of the cooker to the chimney are displayed in the following figure.

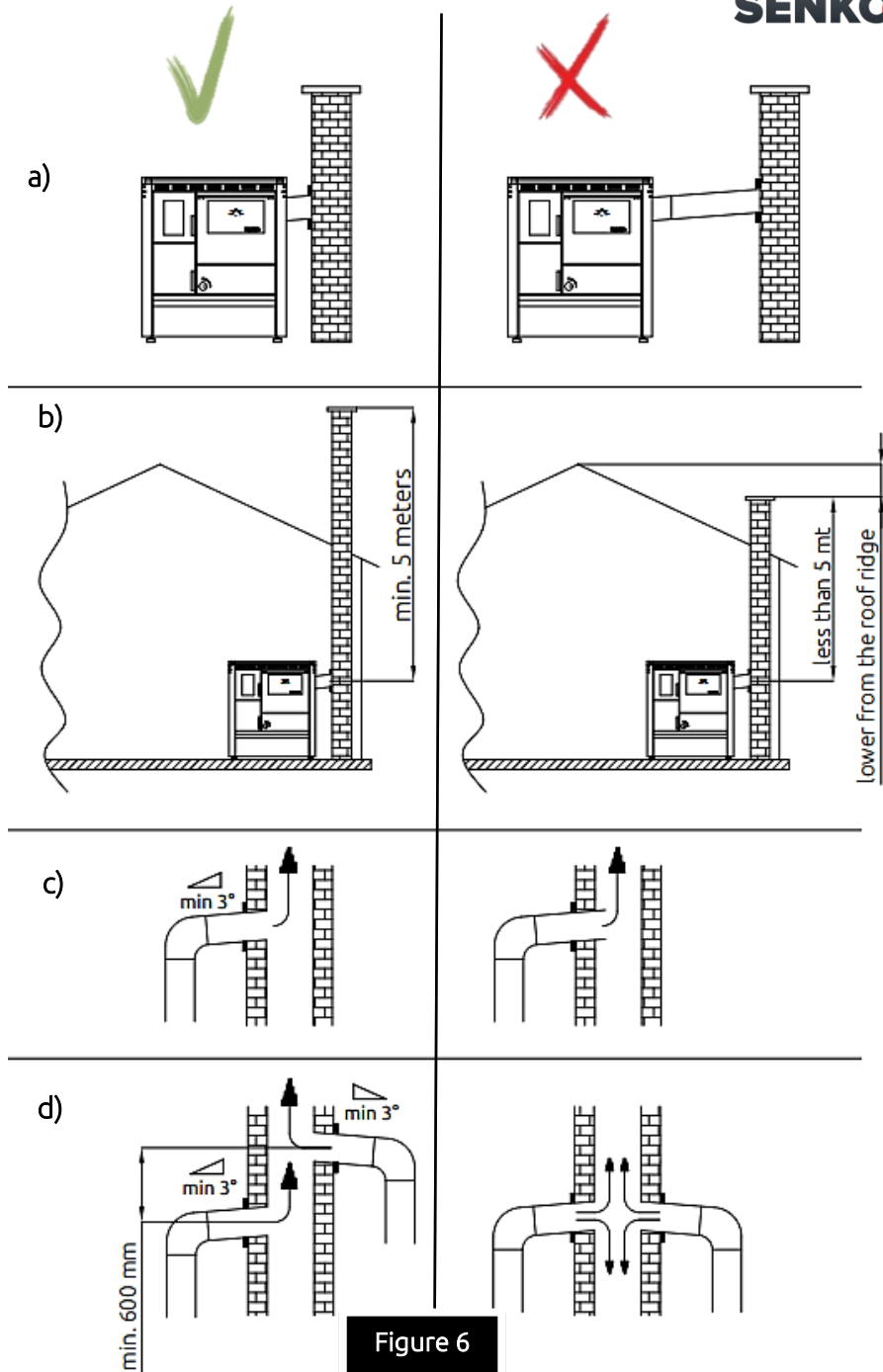

Figure 6

Differences between the proper and improper connection of the cooker to the chimney

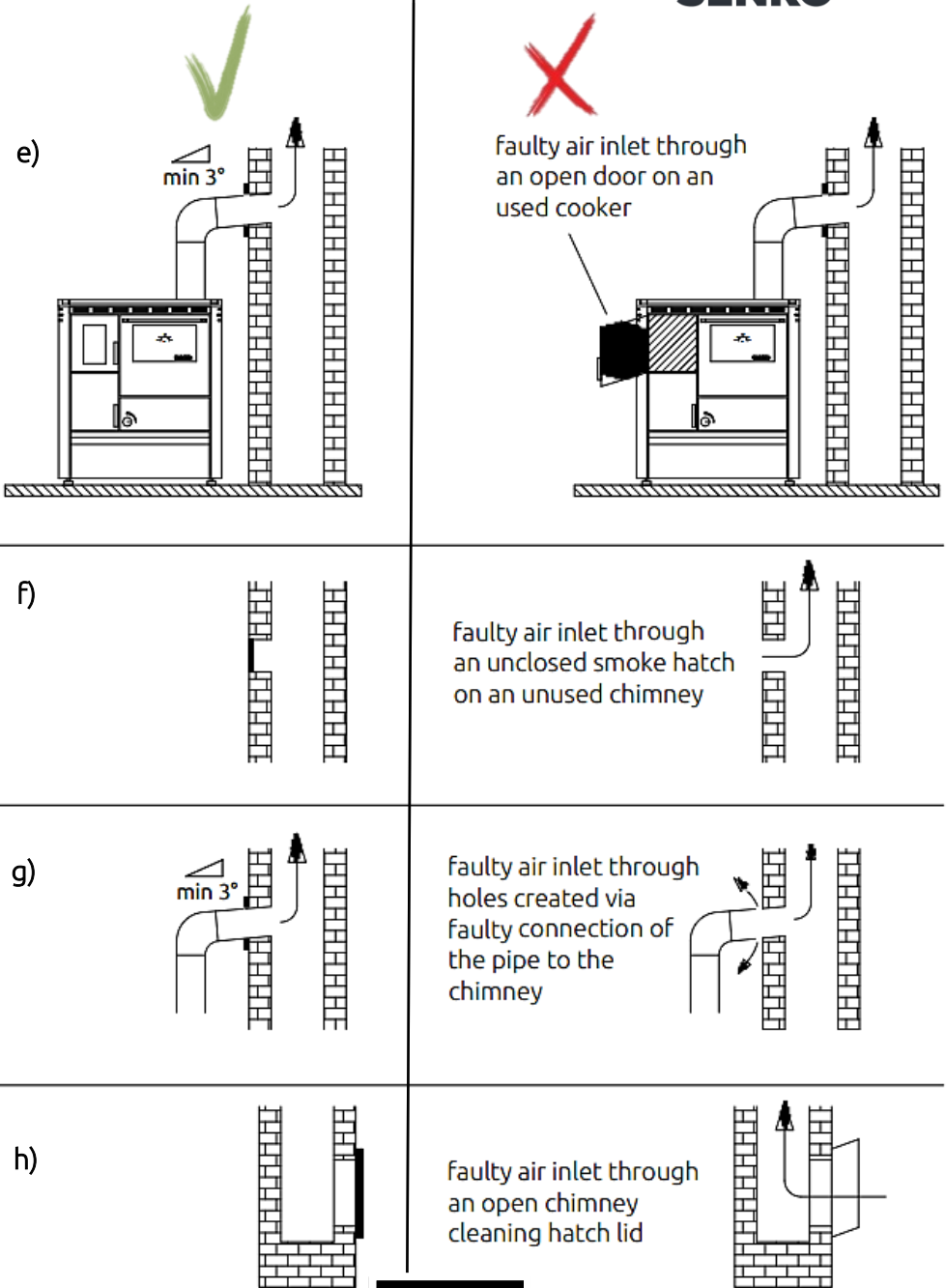

Figure 6



Connect the cooker to the chimney using a sliding rosette, 120 mm in diameter. Specially designed sliding rosette enables the adjustment of the chimney opening in tolerance of 1,5 cm upwards, i.e. downwards.

In case it is necessary to connect the cooker to the chimney with vertical uninsulated pipe, use the smoke outlet pipe, up to 125 cm maximum length.

**It is not allowed to reduce the prescribed pipe diameters!**

If the cooker is further removed from the chimney opening, it is connected via extension tube and an elbow. The extension smoke inlet pipe must have an appropriate incline (see Figure 6) and must not exceed 100 cm in length. The connection of the chimney and the smoke inlet pipe must be completely fastened!



**Figure 7**



1) Remove the external protective lid with a screwdriver

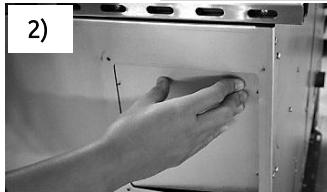

2) Remove the sheet beneath the lid by pressing onto the weakest juncture

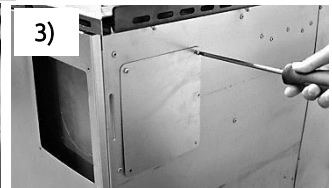

3) Mount the protective lid onto the remaining chimney opening! 



4) Remove the internal protective lid with a screwdriver



5) Install the sliding rosette by using bolts previously used to attach the inner protective lid

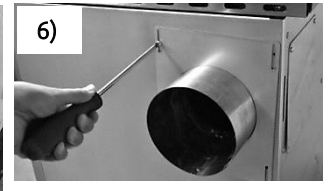

6) Install the external protective sheet by using bolts previously used to attach the external protective lid

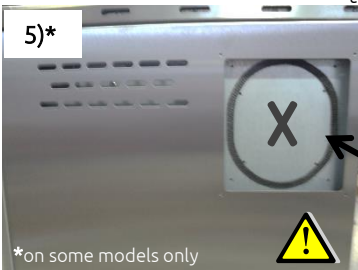

\*on some models only

Before installing the sliding rosette, it is obligatory to stick the self-adhesive strip (provided with your cooker) on the inner sheet metal!

When installing the sliding rosette on the back of the cooker it is necessary to:

- remove the external protective lid with a screwdriver,
- by gently pressing remove the following lid,
- in place of the external lid attach the sliding rosette with the same screws. In doing so, you have remain the external sheet metal of the rosette and external lid (which are at the beginning removed from the cooker), as excess.



#### 4.4. FRESH AIR VENTS

The room where the cooker is installed **must be provided with sufficient air inflow to ensure combustion**. The area must be regularly ventilated.

The fresh air vent must be situated **near the room floor** and allow the inflow of fresh air into the room. **The minimum dimension of the vent must be 6 cm<sup>2</sup> per kW of nominal power** (e.g. for 30 kW  $\Rightarrow$  180 cm<sup>2</sup>  $\Rightarrow$  10 x 18 cm vent).



A pipe can also be installed on the **existing opening Ø80mm on the rear side of the cooker**, for the purpose of entering fresh outside air – see also

Figure 10.

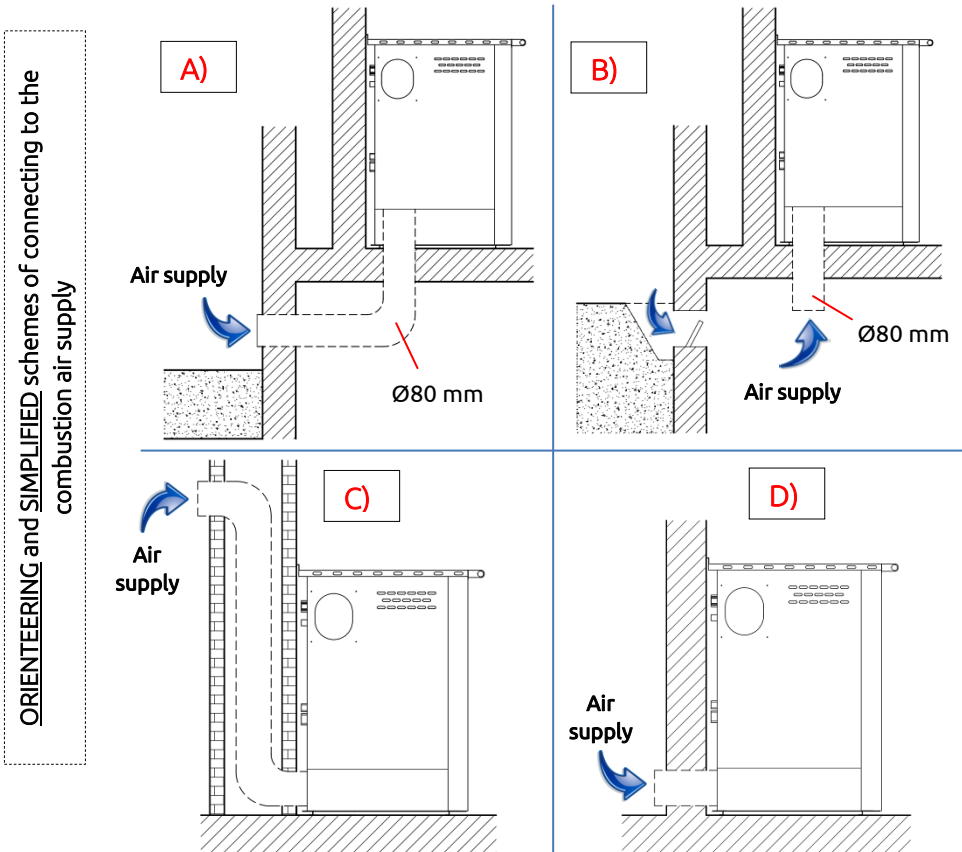



**A) *Combustion air supply via pipe line through a basement room***

The combustion air is preheated with this connection option, which is favorable to a clean combustion. The routing in the basement room is easy to make.



**B) *Combustion air supply via a basement room***

The combustion air is preheated. The basement room must be excluded from the home ventilation system and be open to the outside. High levels of dust and moisture should be avoided.



**C) *Combustion air supply from above***

An air supply from above may only be performed with tested chimney systems. A chimney calculation is mandatory here!



**D) *Combustion air supply directly from outdoor***

With an air supply directly through the outside wall, the combustion air is only slightly preheated, which is unfavorable to a clean combustion. There is also the danger of condensation!



***NOTE: This version of the air supply is not recommended!***

**Please be aware!**

- A prerequisite for the connection of cooker used in combination with domestic ventilation systems is that the approval of the local qualified chimney sweep is obtained!
- It is not permitted to install cut-off devices in the supply air duct (dampers, sliders, etc.). To prevent air from permanently flowing through the appliance when it is not in use, close the dampers in the appliance.

- Make sure that the outdoor air inlet is protected against blockage by means of a protective grating.
- For the supply air duct to the combustion air connecting piece it is best to use a non-combustible, flexible aluminium hose. Max. length 4 m with 3 bends.
- The supply air duct must be insulated to avoid condensation and must be protected against wind!
- According to the regulations for chimney sweeping and inspection ventilation systems must be checked for blockages once a year by the local qualified chimney sweep. To facilitate this, appropriate inspection doors should be provided. Please consult your local qualified chimney sweep regarding this matter.

#### 4.5. OVEN THERMOMETER

Thermometer (18) indicates the oven temperature; this value is informative. **If the oven temperature exceed 300°C, the oven must be partly opened to prevent damage to the thermometer, oven door hinge and oven door.**



**The warranty will be void** in case the damage to the parts listed before occurred from excessive oven temperature.

#### 4.6. INSTALLATION TESTING

**Prior to initial firing** it is necessary to check if the smoke uptake pipe is properly fastened.



## 5. HANDLING THE PRODUCT



⇒ holding the cooker frame is **not allowed** while handling the appliance !

### 5.1. DIRECTING THE FLUE GAS



Flue gas deflector (14) accelerates the expulsion of flue gas from the cooker when this is necessary. It is primarily **used during initial stages of firing or when larger quantities of fuel are added** into the firebox.



**Figure 8**



Flue gas deflector (14) can also be used to regulate the oven temperature (7) ⇒ **if the flue gas deflector is opened (pulled outwards), the oven is cooling.**



## 5.2. AIR ADJUSTMENT AND REGULATION

### CHIMNEY

If the chimney is equipped with a vent damper, it must be adjusted to keep the chimney flue draught within the limitations  $12 \pm 2$  Pa.



### PRIMARY AIR – *cookers SG-75 and SG-90*



Figure 9a

Primary air is the air that flows directly through the firebox grate. There is a manual primary air regulator (10) between the fuel box (12) and ash box (11).

Moving the manual regulator lever you can regulate the flow of primary air from a closed (-) to fully opened (+). Regulator is set in accordance with the desired

temperature in the cooking plate or oven.

There is a round  $\varnothing 80$  mm connection point for the intake of external primary air on the cooker rear side, onto which a pipe can be connected – see Chapter 4.4. and Figure 10.

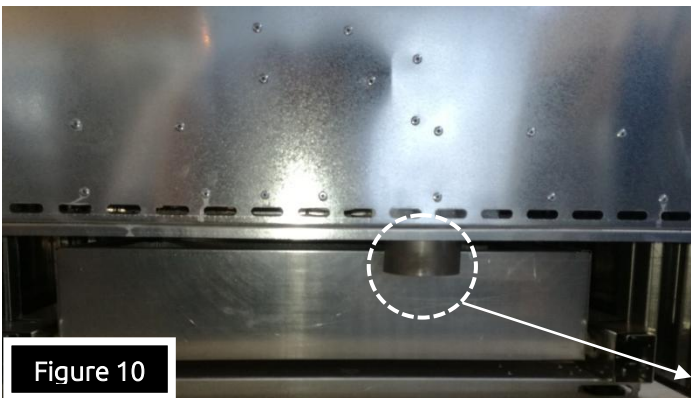
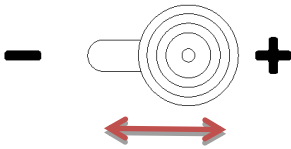

Figure 10

The connecting pipe must be made out of non-flammable material (in accordance with DIN 4102-B1).

primary air connection point (21) on the cooker rear side

PRIMARY AIR – *cooker SG-60*



**Figure 9b**

On the firebox door is **manual primary air regulator (10)**. Moving the regulator lever you can regulate the flow of primary air from a closed (-) to fully opened (+).

There is a **round connection point (21)** for the **intake of external primary air** on the cooker rear side, onto which a pipe with **diameter of 80 mm** can be connected.

SECONDARY AIR

Secondary air is the air that flows into the firebox to facilitate maximum combustion, reducing harmful substances to ashes and discharging flue gas with low capacity for pollution into the chimney.



Regulation of secondary air is **automatic** through the holes that are located in chamotte plates in the firebox (*Figure 11a*).

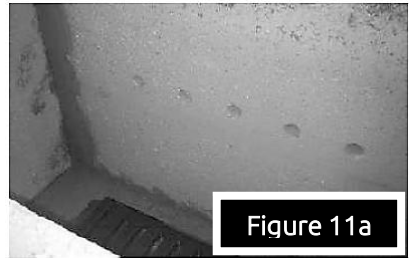

**Figure 11a**

Moving the manual regulator lever you can **regulate the flow of secondary air**



<i>only at cookers SG-75 and SG-90</i>	LEFT = OPEN
	RIGHT = CLOSED

At SG-60 the regulation is automatic.

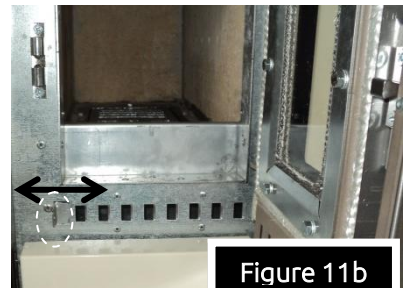

**Figure 11b**

**5.3. FIREBOX GRATE**



Firebox grate is movable (only at cookers SG-75 and SG-90). It moves by a handle (15) which is located to the right of the left cooker firebox respectively, to the left of the right cooker firebox.

By moving the grate **can be further controlled a primary air inlet**, for better and

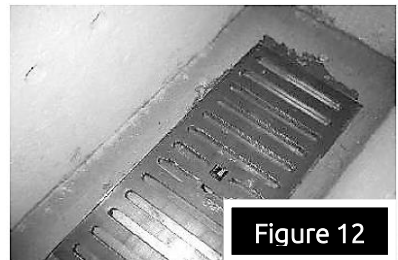

**Figure 12**

slower fuel burning. When the handle (15) is pulled out – the grate is open, otherwise it is closed.



- wide grate openings must be positioned facing downwards at all times to allow the ashes to fall down !



## 5.4. FIRING

### 5.4.1. PROCEDURE

Prior to every firing, follow the following procedure:

- if the chimney is equipped with a vent damper, open it completely,
- open the flue gas deflector (14) and set the manual primary air regulator (10) to maximum,
- open the firebox door (6) (maximum door opening angle is 90°),
- put the kindle wood into the firebox and ignite it,
- close the firebox door (6),
- monitor flame progression through the firebox door,
- once the fire is in full flame, add wooden logs as necessary,
- close the flue gas deflector (14),
- regulate the fire intensity by regulating the volume of primary air via manual regulator (10).



**WARNING!** Never use flammable liquids, such as petrol and similar to ignite the fire and always keep these and similar liquids away from your cooker.



### 5.4.2. OPTIMUM USE VALUES

Primary air volume and chimney flue draught must be adjusted to levels that prevent oven temperature from exceeding 300°C.



Maximum quantity of fuel that can be accommodated in the firebox:

- 2-3 kg (wood); 1,5-2 kg (briquettes).

Adding fuel in regular intervals, in quantities of 0,5 to 1 kg, is recommended.





When using the oven for baking, it is recommended (to maintain constant temperature in the oven) to add 0,5 kg of fuel in regular intervals. It is also recommended to rotate the tray from 180° halfway through the baking process to ensure uniform baking!



Cooker optimum values may be achieved only if the cooker nominal power was chosen in accordance with the rules of profession and object energetic efficiency.

### 5.4.3. ADDING FUEL

Apart from use of appropriate fuel and satisfactory chimney flue draught, the manner in which the cooker is fuelled **also influences the glass cleanness**.



We recommend only **one layer in each fuel refill** and, if possible, the **use of logs of length up to 2/3 of the firebox length**. There should be a minimum distance of 1-2 cm between the logs.

**Figure 13**

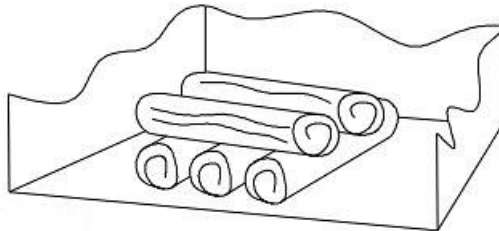

Briquettes should be used in amount that only covers the firebox surface, also with a **minimum distance of 1-2 cm** between them.



**WARNING!** New fuel quantities should be added only on top of embers, i.e., not on the flames, but only on top of embers (approx. 1 cm thick).

Primary air manual regulator (10) must be completely closed at least 1 minute before opening the firebox door (6) to prevent the breach of flue gases into the residential area.



The door must be opened slowly. After adding the fuel, close the door slowly. Open the primary air manual regulator (10) to decrease the time of fuel combustion.

Once the fuel starts burning, adjust the primary air manual regulator (10) to a desired position ⇒ in accordance with *chapter 5.2*.

**Flue gas deflector (14) MUST BE opened before opening the door!**



#### 5.4.4. FEEDING IN TRANSITION PERIOD

During the transition period, i.e. **when outdoor temperatures are higher**, sudden increase in outdoor temperature can **cause chimney malfunction** (decreased chimney flue draught) resulting with not all flue gases being expelled into the atmosphere.

It is therefore recommended to **use less fuel and smaller logs** during the transition period in order to achieve a more lively flame, as well as to **adjust the primary air volume** in order to improve the expulsion of flue gases from the chimney.



#### 5.5. OVEN DOOR

Oven door are removed as shown in the following figure:



- ◆ open the oven door all the way
- ◆ move the safety all the way back on the left and right oven hinges

- ◆ close the door halfway ensuring that the safeties lean against the door slits

- ◆ lift the ajar door (for around 15°) upwards for approx. 2 mm and lightly pull them towards yourself, inclining the door toward the cooker simultaneously
- ◆ pull the door from the cooker hinge bearing

**Figure 14**

**Reverse the procedure to mount the door back!**





**WARNING!** Always make sure that the hinge safeties properly fit in their bearings prior and after the removal of door! Otherwise they might suddenly pop out during door removal or mounting, i.e. the hinge might suddenly close due to strong springs, which might cause injuries!



The oven door hinges must be periodically (at least once a year) lubricated with grease resistant to high temperatures (up to 400°C)!

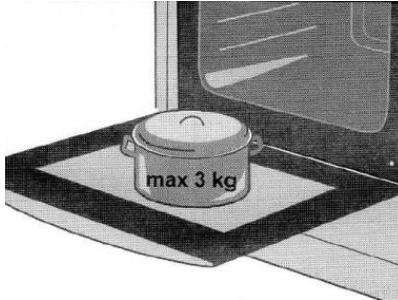

Oven door hinges can be damaged when overload, so on the open oven door do not stack hard cooking utensils (max 3 kg) and do not lean against the doors while cleaning the inside of the oven!

At the open door may not fit with your foot or sit on them (children)!



## 5.6. FUEL BOX

Fuel box (12) is mounted on the guide bars. **Maximum bearing capacity of the box is 15 kg.** The box is removed as follows:

- pull the box towards yourself all the way,
- lift the box upwards for approx. 5 mm and lightly pull towards yourself.
- the box is mounted back by reversing the procedure!



**Figure 15**



**Easily flammable or explosive objects must not be stored in the box !**

## 5.7. HEIGHT ADJUSTMENT

On the cooker base (3) there are 4 feet with screw to adjust the height 850 – 920 mm of the cooker.

Adjustment is made by turning the screw M10 to the desired height. After that, the M10 nut needs to be tightened with a wrench OK17 to avoid damaging of the feet.

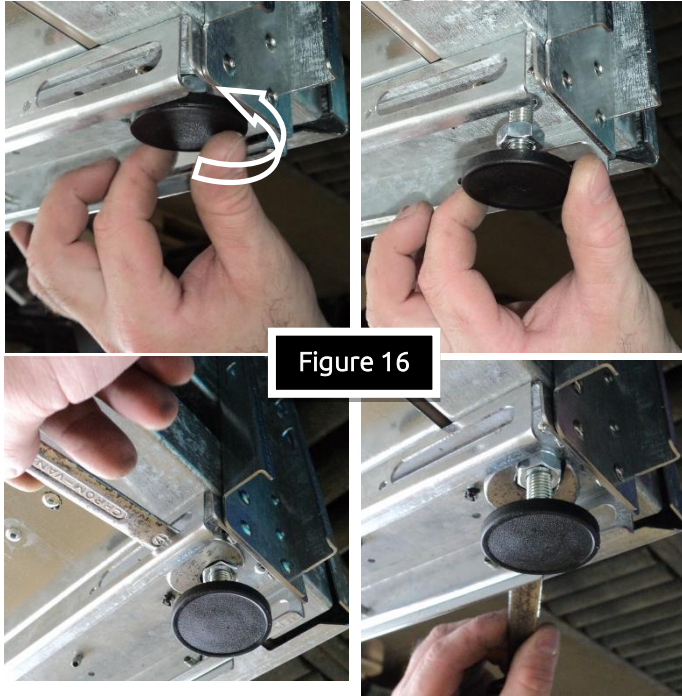

Figure 16

## 6. CLEANING

The cooker and the chimney must be regularly cleaned (at least once a month).

The ash box (11) and the box area must be cleaned on daily basis. Ash disposal is to be executed in environmentally acceptable manner and in accordance with safety procedure.

The glass (20) on the upper firebox door (6) should be cleaned as necessary using the soot and grease cleaning agent.



The oven (7) should be cleaned after every instance of use.

To clean the exterior surface, use a soft cloth with a neutral cleaning fluid. Never use metallic sponges and / or other similar sponge to avoid damaging the surface! PAINTED SURFACES DO NOT CLEAN WITH ABRASIVE CLEANING AGENTS!



While cleaning the top side of the cooker, it is necessary to remove the cooking plate (1) and thoroughly clean the soot from the firebox, around the oven and flue gas deflector, including the chimney outlet opening (13).

Cooker cleaning is to be performed only when the cooker is inactive and when it is cold!



## 6.1. CLEANING THE FLUE GAS CHANNEL

### 6.1.1. COOKERS SG-75 and SG-90

When cleaning the flue gas channel, adhere to the following procedure:

- remove the cleaning hatch lid (9) by pulling it towards yourself ⇒ *Figure 17a*,
- remove the protective lid by unscrewing the 4 screws ⇒ *Figure 17b*,
- clean and remove the soot and ashes from the cooker inside (*Figure 17c and d*) using a cooker cleaning tool (23). After thorough cleaning, mount back the protective lid and cleaning hatch lid back into their positions.



a)



b)

Figure 17



c)



d)



### 6.1.2. COOKER SG-60

When cleaning the flue gas channel, adhere to the following procedure:

- remove the cooking plate (1),
- remove the grate (16) from the firebox ⇒ *Figure 18a*,
- by unscrewing the 4 screws remove the protective lid and clean the area underneath ⇒ *Figure 18b*,
- remove the oven door (according to *chapter 5.5*) and the fuel box (according to *chapter 5.6*),
- remove the protective lid by unscrewing the screws ⇒ *Figure 18c* and *d*,
- with cooker cleaning tool (23) clean the area under the oven ⇒ *Figure 18e* and *f*.

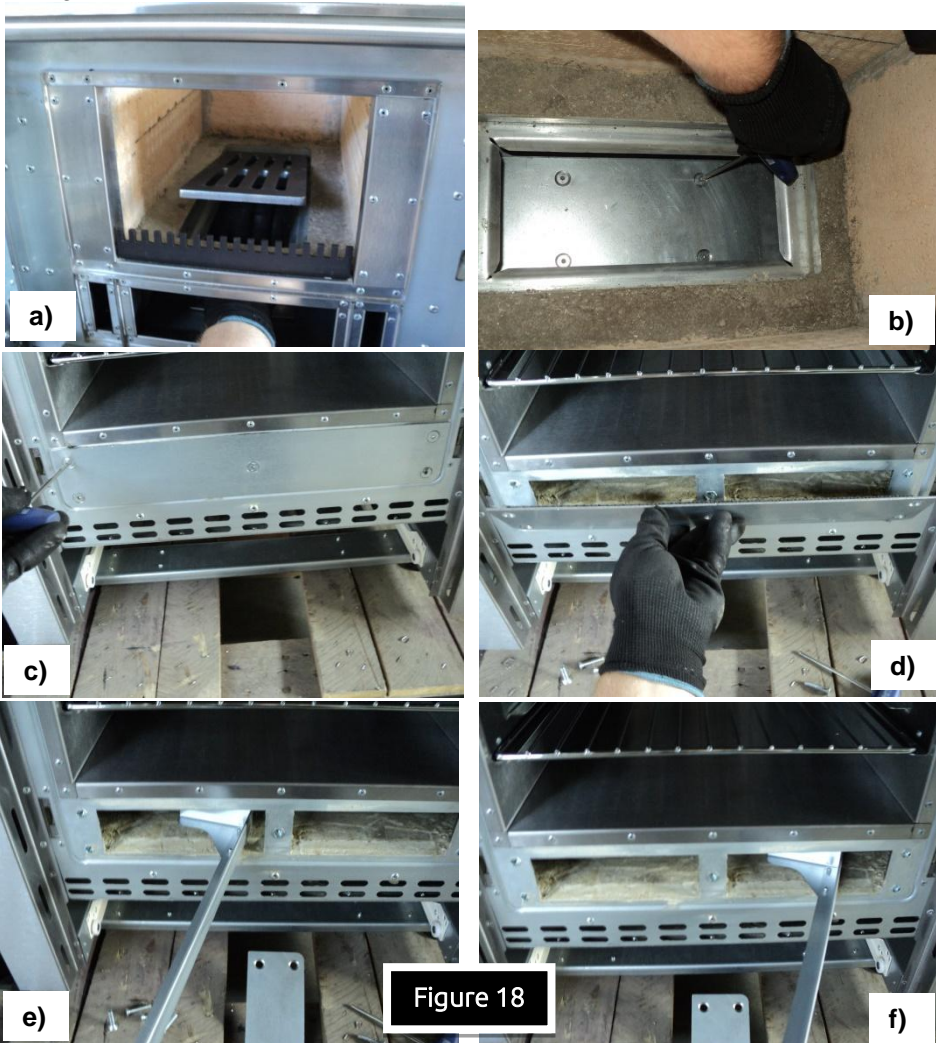

## 7. MAINTENANCE



During the cooker use, the **chamotte insulation** (consumable material) suffers natural damage that must be repaired with chamotte putty. **It is not necessary to remove the chamotte insulation from the cooker.**



**During delivery, cooking plate is coated with protective paint.** After a few hours of the first firing protective paint on the cooking plate will burn out causing an unpleasant smell. The smell disappears after a few hours of firing. **The plate took on a greyish - operating color.** This is **normal phenomenon and has no effect on plate lifespan**



During the non-use of the cooker, it is IMPORTANT that **the cooking plate is smeared with a cloth dipped in edible oil** because due to moisture on the plate it may appear the layer of rust.



**Stainless material on the cookers** is susceptible to slight colour change due to high temperatures. **Stainless materials are to be maintained exclusively with stainless material maintenance agents in accordance with the manufacturer's instructions.**



Handle **securing bolt** on upper and lower doors and **firebox door protective bolt** to be tightened if necessary.

### GLASS CERAMIC COOKING PLATE

*- only at certain cooker models*



Glass ceramic cooking plate by SCHOTT is **extremely temperature resistant** and withstand even abrupt temperature shocks **up to 700°C**. It is insensitive to normal mechanical loads in the kitchen. CERAN® cooking surface is **easy to clean**.



- It should be cleaned **only when completely cooled down**, preferably after each use - with kitchen paper towels or a clean cloth

- For regular cleaning use special glass ceramic cleaning agents which creates a protective layer on the surface
- **NEVER** use abrasive or aggressive cleaning agents such as grill and baking oven sprays, stain and rust remover, sponges with abrasive surface !
- Before each use, wipe the dust and other particles from the cooking plate, as such deposits can damage the surface
- Hard and baked stains must be removed with a **scraper for glass-ceramic**
- If anything (**sugar or food containing sugar** etc.) has burnt-in on the cooking surface by mistake, this **must be removed immediately (while hot)** to avoid surface damage.



Changing the color of the plate has no effect on its performance and efficiency!



## 7.1. OLD COOKER DISPOSAL

Once the cooker is no longer fit for use it must be delivered to an authorized disposal service specialized in recycling this type of waste. **It is forbidden to dispose of the old cookers in the natural environment!**



## 7.2. SPARE PARTS

**Only original spare parts by the manufacturer are to be used.** Should non-original spare parts be used or should the repair be executed by an unauthorized individual, the warranty will be void.





## 8. MALFUNCTIONS / CAUSES / SOLUTIONS

PROBLEM	POSSIBLE CAUSE	SOLUTION
Firebox door glass is black and/or the firebox is smoky (black soot)	<ul style="list-style-type: none"><li>◆ insufficient flue draught (less than 10Pa)</li><li>◆ faulty regulation</li><li>◆ too much fuel in the firebox</li><li>◆ fuel too moist</li><li>◆ inadequate fuel</li><li>◆ excessive firebox temperature</li></ul>	<ul style="list-style-type: none"><li>⇒ check the connection of the cooker with the chimney and the chimney</li><li>⇒ study <i>chapters 4.2 and 4.3</i>.</li><li>⇒ study <i>chapter 5.2</i>.</li><li>⇒ reduce the fuel quantity</li><li>⇒ use fuel with less than 17% of relative moisture</li><li>⇒ use fuel as described in <i>chapter 1.1</i>.</li><li>⇒ reduce the fuel quantity and primary air volume and adjust chimney flue draught in accordance with <i>chapter 5.2</i></li></ul>
Insufficient flue draught in the chimney; black smoke expelled from the chimney	<ul style="list-style-type: none"><li>◆ chimney filled with soot</li><li>◆ cooker filled with soot</li><li>◆ chimney partially clogged or filled with soot</li><li>◆ fuel not sufficiently dry</li><li>◆ firebox cast grate turned in the wrong direction</li><li>◆ upper or lower door opened</li><li>◆ inadequate flue draught</li><li>◆ faulty regulation</li></ul>	<ul style="list-style-type: none"><li>⇒ clean the chimney</li><li>⇒ clean the cooker</li><li>⇒ unclog and clean the chimney</li><li>⇒ use fuel in accordance with <i>chapter 1.1</i>.</li><li>⇒ set the grate in accordance with <i>chapter 5.3</i>.</li><li>⇒ close the door</li><li>⇒ adjust the flue draught in accordance with <i>chapter 4.2</i>.</li><li>⇒ adjust the primary and secondary air in accordance with <i>chapter 5.2</i>.</li></ul>
Smoke coming out of the cooker	<ul style="list-style-type: none"><li>◆ cooker filled with soot</li><li>◆ chimney filled with soot</li><li>◆ fuel too moist</li><li>◆ low calorie fuel</li><li>◆ levels of fresh air in the room too low</li><li>◆ firebox temperature too low</li><li>◆ chimney lower than 4.5 m</li><li>◆ chimney diameter smaller than the one prescribed</li></ul>	<ul style="list-style-type: none"><li>⇒ clean the cooker as described in <i>chapter 6</i>.</li><li>⇒ clean the chimney as described in <i>chapter 6</i>.</li><li>⇒ use fuel as described in <i>chapter 1.1</i>.</li><li>⇒ study <i>chapter 4.4</i>.</li><li>⇒ increase the firebox temperature by increasing fuel quantity</li><li>⇒ adjust the chimney in accordance with <i>chapters 4.2 and 4.3</i>.</li></ul>
Cooking and baking temperature too low	<ul style="list-style-type: none"><li>◆ insufficient or excessive chimney flue draught</li><li>◆ excessive primary air volume</li></ul>	<ul style="list-style-type: none"><li>⇒ adjust the chimney flue draught in accordance with <i>chapter 4.2</i>.</li><li>⇒ reduce primary air volume</li></ul>

	<ul style="list-style-type: none"> <li>◆ inadequate fuel</li> <li>◆ too much fuel – combustion difficult</li> <li>◆ flue gas deflector opened</li> <li>◆ grate in closed position</li> </ul>	<ul style="list-style-type: none"> <li>⇒ use fuel as described in <i>chapter 1.1.</i></li> <li>⇒ add less fuel to the firebox</li> <li>⇒ close the flue gas deflector</li> <li>⇒ set the grate into the open position</li> </ul>
<p><b>Cooking and baking temperature too high</b></p>	<ul style="list-style-type: none"> <li>◆ excessive chimney flue draught</li> <li>◆ inadequate fuel</li> <li>◆ flue gas deflector closed</li> <li>◆ grate in the fully open position</li> </ul>	<ul style="list-style-type: none"> <li>⇒ reduce the chimney flue draught in accordance with <i>chapter 4.2.</i></li> <li>⇒ use fuel as described in <i>chapter 1.1.</i></li> <li>⇒ open the flue gas deflector</li> <li>⇒ adjust openness of the grate as required</li> </ul>

## 9. TECHNICAL SUPPORT

Dear client,

If you were unable to find the solution to the malfunctions, that potentially developed while using your product, in the table above, please feel free to contact our complaint and support service:

- Tel.: +385 (0)40 337 344
- Fax.: +385 (0)40 337 906
- E-Mail: [info@senko.hr](mailto:info@senko.hr), [podrska@senko.hr](mailto:podrska@senko.hr)

WE'D LIKE TO TAKE THIS OPPORTUNITY TO REMIND YOU WHAT YOU NEED TO POSSES WHEN CONTACTING OUR COMPLAINT AND SUPPORT SERVICE:

Before you contact us, prepare the following documents:

- **purchase receipt with the date of purchase,**
- **warranty** (at the back of this *Manual*),
- **written installation report** (at the back of this *Manual*),
- **Instruction manual.**



The documents listed above are necessary to ensure the quickest and clearest removal of the occurring malfunction!

## 10. TECHNICAL DATA

SENKO cooker		SG-60	SG-75	SG-90
Nominal heat output, kW		9	7,5	
Room, kW		9	7,5	
Width, mm		600	750	900
Depth, mm		650		
Height, mm		850-920		
Weight, kg		170	135	170
Firebox opening (W × H), mm		215×160	165×230	
Firebox (W × D), mm		225×355	205×425	
Firebox volume, dm <sup>3</sup>		17,5	27,4	
Fuel consumption, kg/h		2		
Cooking plate (W × D), mm		494×473	667×492	817×492
Cooking plate area, m <sup>2</sup>		0,234	0,328	0,401
Oven (width), mm		360	330	400
Oven (height), mm		200	270	230
Oven (depth), mm		440		
Ash pan, L		3,2	2,5	
Fuel box, L		13,3	25,4	41,1
Flue gases exhaust, mm		Ø 120		
Flue gas temperature, °C		215	260	235
Required flue draught, Pa		12		
CO in flue gases at 13% O <sub>2</sub> , %		0,12	0,16	
Flue gas mass flow rate, g/s		9,4	10,6	
Efficiency, %		81	72	
Regulation	Primary air	manual		
	Secondary air			
Produced in accordance with EN norm		EN 12815		
Energy efficiency class		A+	A	A

- technical specification apply to wood logs and wooden briquettes used as fuel
- technical specifications are indicative and may vary as such. The manufacturer withholds the right to change any technical specification to further improve the products

## 11. TERMS OF WARRANTY

These warranty conditions are valid in all European countries, in which SENKO products are sold. The client addresses the manufacturer/dealer or the nearest authorized servicing agent for all complaints; providing the purchase receipt with the date of purchase, warranty and installation report in the process.

### DURATION OF THE WARRANTY

Manufacturer SENKO d.o.o. provides a **2-year** warranty for its product, in the case of production faults and construction materials. Oven thermometer, oven grid, manual regulator, regulation buttons, oven door hinges, fuel box guide bars) have a **6-months** warranty.

The manufacturer guarantees that the product was produced according to the EN 12815 norm and that it complies with all the demands set by the norm. The user is obligated to adhere to the instruction manual.

### EXCEPTIONS

Exceptions are parts subject to wear such as chamotte and chamotte plates, cast grate, ash box, seals and glass panes.

**Chamotte plates** (changes in colour or cracks are dependent on the material and can never be completely ruled out). However, they do not impair the functioning of the appliance (as long as the plates remain in the firebox) and they are not a motive for complaint.

**Glass panes** (breakage of glass because of external hazard, changes on the surface due to thermal influences such as fly-ash or soot at the surface of the glass).

**Discolouring** of paint due to overload of thermal strain.

**Seals** (e.g. hardening or breakage due to thermal or mechanical strain).

**Surface coatings** (frequent cleaning or cleaning with abrasive cleaning agents).

**Castings** and parts which are subject to high thermal stress such as firebox grate, cooking plate or ash box.

**Heat exchanger (boiler)** is not subject to the warranty in the event in which it is not secured with adequate anti-condensate circuit which guarantees a minimum return water temperature of at least 55°C (*only at central heating cookers*).

### REPAIRS

Possible repairs within the warranty will be executed within 30 days from the date of product delivery to the manufacturer. Should the repairs not be executed within 30 days from the delivery to the manufacturer, the product will be replaced with a new one. The manufacturer will notify the client about the executed repairs. The client is obligated to take over the product within 5 days from the repair completion.

### COSTS

The manufacturer does not defray any delivery and return costs.

Prior to commencement of repairs within the warranty (for damages caused by incorrect use, cooker transport and mounting), the manufacturer will notify the client about the repair price in written form. Once the client agrees, the manufacturer will execute the repairs and charge the client for the repairs.

### SPARE PARTS

Original parts replaced within the warranty do not have to match the removed parts in external physical appearance, but they must match them in quality and functionality.

### DISCLAIMER OF LIABILITY

Manufacturer cannot accept any liability for the loss or the damage of an appliance through theft, fire, vandalism or similar causes. Indirect or direct damage caused to the product, which is the result of improper transportation of the product, are excluded from the liability. We cannot accept any liability for damages caused by chemical or electrochemical effects (e.g. pollutants in the combustion air and similar) which are the result of improper installation of the product and violation of this instruction manual.

### ADDITIONAL TERMS

Small dimensional differences in construction materials and parts of the cooker are not a reason for complaint. During the period in which the product was inefficient, we will not grant any compensation. This warranty applies only to the customer specified in the warranty sheet and cannot be transferred to others.

**The warranty is void** if the user made alterations to the product without manufacturer's prior knowledge. If the user was negligent and performed maintenance on the wrong way. If the user is using fuel that is not compliant with the types and quantities indicated in this Manual

**The warranty is valid if the installation was executed by an authorized professional and upon presenting the written installation report.**

Possible disputes to be settled by the competent Court in Čakovec.

WARRANTY No.

SOLID FUEL COOKER:

E 2375 L SG-75     E 2375 D SG-75     E 2675 L SG-75

E 2675 D SG-75     E 2390 L SG-90     E 2390 D SG-90

E 2690 L SG-90     E 2690 D SG-90     E 2560 SG-60     E 2860 SG-60

SERIAL NUMBER: \_\_\_\_\_

DATE OF MANUFACTURE: \_\_\_\_\_

STORE NAME  
AND ADDRESS: \_\_\_\_\_  
\_\_\_\_\_

CLIENT NAME  
AND ADDRESS: \_\_\_\_\_  
\_\_\_\_\_

DATE OF PURCHASE: \_\_\_\_\_

STORE STAMP AND  
DEALER SIGNATURE: \_\_\_\_\_

Complaints within warranty – product information:

Faulty product date of receipt: _____
Malfunction description (client): _____ _____ _____
Servicing agency comments: _____ _____
Servicing completed on date: _____
Stamp and servicing technician signature: _____

Faulty product date of receipt: _____
Malfunction description (client): _____ _____ _____
Servicing agency comments: _____ _____
Servicing completed on date: _____
Stamp and servicing technician signature: _____



COMPLETED BY THE CHIMNEY-SWEEPER

### Chimney connection executed by the company :

Company/Business: \_\_\_\_\_ Person in charge: \_\_\_\_\_  
stamp and signature

Street: \_\_\_\_\_ City: \_\_\_\_\_

Telephone: \_\_\_\_\_ Country: \_\_\_\_\_

Date: \_\_\_\_\_ Client signature: \_\_\_\_\_

### Chimney

Type: .....

Dimensions (mm): .....

Height (m): .....

Draught (Pa): .....

Flue gases exit temperature (°C): .....

Last inspection date: .....

Number of connections: .....

### Smoke venting pipe (if connected)

Cross-section (mm): .....

Length (m): .....

Number of elbows: .....

### Air supply pipe (if connected)

Cross-section (mm): .....

Length (m): .....

Number of elbows: .....



Senko d.o.o.  
 Vladimira Nazora 22, Štefanec  
 40 000 Čakovec, Republic of Croatia  
 12

**EN 12815:2001 / A1:2004 / AC:2007**

Solid fuel cookers

	SG-75	SG-90
Minimum distance from flammable surfaces:	above 100 cm front 80 cm rear 20 cm sidebar 20 cm	
CO emission in flue gases (at 13% O <sub>2</sub> ):	0,16 %	
Flue gases temperature:	260 °C	235 °C
Heat output – space:	7,5 kW	
Efficiency:	72 %	
Fuel type:	wood logs, wood briquettes	
Fuel consumption:	2 kg/h	
Certificate No:	E-30-00434-12	

Read and follow the Instruction manual. Use only recommended fuel.  
**Manufactured in the Republic of Croatia**

---

### DECLARATION OF CONFORMITY

This product is certified in accordance with the EN 12815. Test report number 30-11665/3 from June 29<sup>th</sup>, 2012.

---



# SENKO

---

Vladimira Nazora 22, Štefanec, 40000 Čakovec, Hrvatska  
Tel: +385 (0)40 33 73 44 • E-mail: info@senko.hr

**www.senko.hr**

---



*... THE SPIRIT OF TRADITION  
IN MODERN FORMS FOR  
A HEALTHY ENVIRONMENT.*

facebook

YouTube



You can find this Manual at <http://en.senko.hr/>